

# NIR BORESCOPE 3XR

THERMAL IMAGING SOLUTIONS  
FOR REFORMER AND CRACKER TUBE FURNACES

ATEX, IECEx and CSA HAZARDOUS AREA CERTIFIED

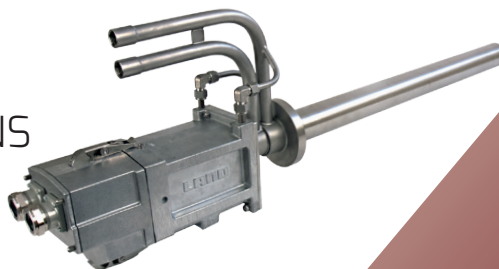

① 600 to 1800 °C / 1112 to 3272 °F



**LAND**  
**AMETEK**<sup>®</sup>  
PROCESS & ANALYTICAL INSTRUMENTS



QUALITY CUSTOMER SOLUTIONS

# NIR BORESCOPE 3XR

**AMETEK LAND HAS BEEN MANUFACTURING PRECISION MEASURING EQUIPMENT SINCE 1947.**

**We are specialists in non-contact temperature measurement and combustion monitoring with our products finding applications across diverse industries such as steel and glass making, power generation, cement manufacture and hydrocarbon processing.**

As part of AMETEK Process & Analytical Instruments Division since 2006, our customers benefit from the worldwide AMETEK sales and service team.

The NIR Borescope (NIR-B) 3XR is a short wavelength radiometric infrared borescope imaging camera for steam reformer and cracker tube continuous temperature measurement and furnace optimisation and monitoring. ATEX and IECEx approved to Ex nA IIC T4 Gc for use in Zone 2 gas atmospheres, and CSA Certified for US and Canada to Class I, Division 2, Groups A, B, C, D T4, the NIR-B 3XR provides a high resolution thermal image with real time continuous high accuracy temperature measurements of both the tube wall and refractory wall surface. The camera measures temperatures in the single range 600 to 1800 °C (1112 to 3272 °F) and utilising the latest wide dynamic range imaging technology. This is ideal for applications with a high differential temperature in the field of view such as tube and furnace walls.

Building on more than twenty years of thermal imaging experience, AMETEK Land has continued to widen its range of temperature measurement solutions by launching the NIR Borescope 3XR. With the NIR-B 3XR it is possible to use the proven technology of the NIR Thermal Imager to accurately and continuously profile the temperature of the reformer, improving data accuracy through automation and at the same time reducing the risk to personnel by removing the need for an operator to be in the hazardous area on a regular basis. The NIR-B 3XR uses the shortest wavelength

to minimise errors associated with varying emissivity, allowing highly accurate temperature measurement point data to be taken, stored and trended over the lifetime of the reformer or cracker. The image and data processing software supports long term data trending, allowing process optimisation to be achieved, combined with potentially avoiding catastrophic failure.

The high resolution image combined with the wide angle field of view (90-degree) allows multiple reformer or cracker tubes in the lane to be imaged and measured simultaneously. With advanced digital communications the image and data can be viewed real-time in the control room in the safe area. The image also allows the user to monitor and optimise the performance of the furnace; easily identifying hot and cold areas and any uneven heating and gas mix can be visualised with corrections viewed in real-time. During start-up phases any burners that are not operating correctly can be clearly identified and the effect of any impinging flames can be seen.

The NIR-B 3XR is an invaluable tool in prolonging reformer tube life time, optimising production throughput and reducing energy consumption.

## FIELD OF VIEW LENS OPTION

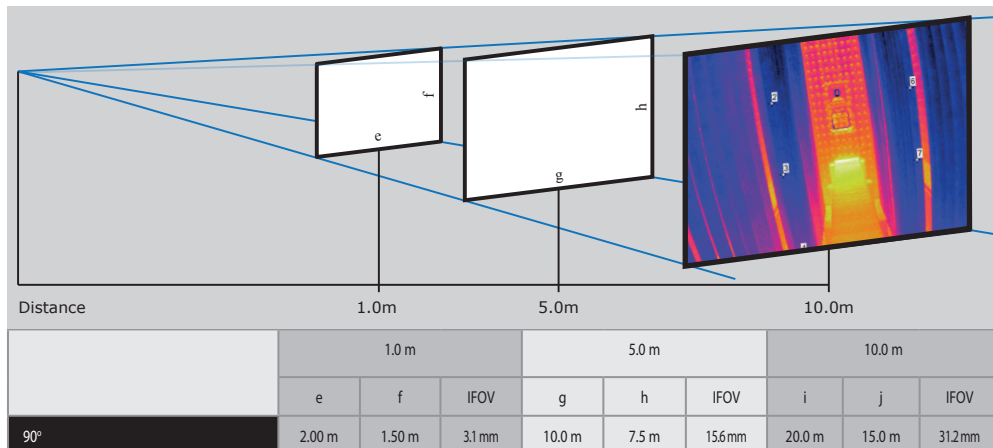

# SPECIFICATION & DESIGN

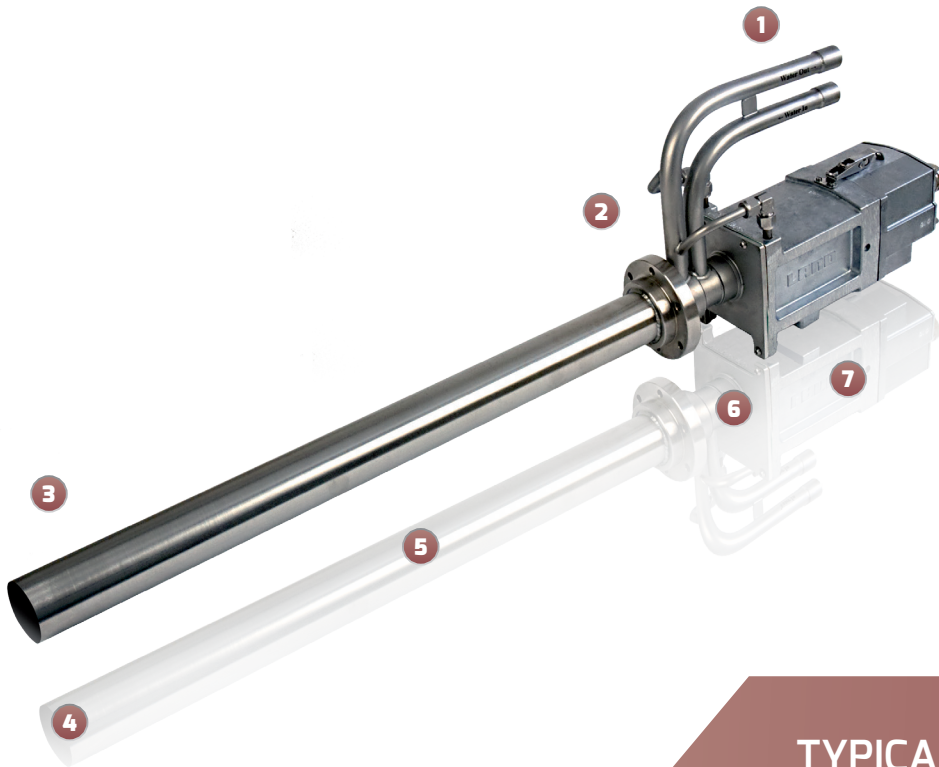

## 1: HIGH PERFORMANCE WATER COOLING SYSTEM

The low water flow requirements for our cooling systems, even in the highest temperature furnaces equal low running costs

## 2: RANGE OF MOUNTING OPTIONS

The most common mounting options available to ensure simple installation

## 3: THERMOCOUPLE AT NIR-B 3XR TIP

Giving the operator an alarm for removing the instrument preventing damage if maximum temperatures are exceeded

## 4: VIEWING ANGLE

90° angle provides thermal view of multiple tubes. 640 x 480 resolution gives 307,200 data points

## 5: PROBE LENGTHS

Range of probe lengths create the best fit for reformer installations

## 6: INTEGRATED AIR PURGE

Our air purge design maintains a clean lens in harsh process environments while consuming minimal instrument air

## 7: HAZARDOUS AREA CERTIFICATION

ATEX and IECEx approved to Ex nA IIC T4 Gc for use in Zone 2 gas atmospheres, and CSA Certified for US and Canada to Class I, Division 2, Groups A, B, C, D T4

## TYPICAL APPLICATIONS

Hydrogen Reformer

Ammonia Production

Ethylene Cracking Furnaces

Methanol Production

Syngas Production

## VIEW OF REFORMER TUBE

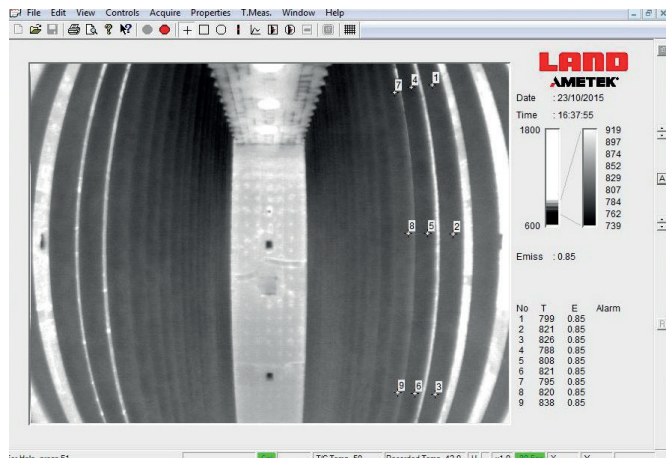

## FEATURES & BENEFITS

**High temperature measurement accuracy** - enables optimum process control through enhanced thermal imaging

**Real-time thermal data - combined with high resolution visual image** - allows true real-time furnace optimisation and the opportunity to improve energy efficiency without degrading reformer lifetime

**Short wavelength sensor** - low sensitivity to emissivity changes

**Dedicated software** - data points, areas of interest, automated alarms and long term data trending and system inter-connectivity (DCS, OPC)

**24 Hour, 7 Day Monitoring** - Shutterless operation guarantees accurate, reliable data with no blind time

**Export License Free** - rapid, hassle-free shipping

**3 Year Warranty** - guarantee of reliability

# NIR BORESCOPE 3XR

THERMAL IMAGING SOLUTIONS  
FOR REFORMER AND CRACKER TUBE FURNACES

## SPECIFICATIONS

<b>Measurement Range:</b>	600 to 1800 °C / 1112 to 3272 °F
<b>Spectral Response:</b>	0.85 to 1.05 µm
<b>Frame Rate:</b>	7.5 fps (100M Ethernet)
<b>Image Pixels:</b>	640 x 480
<b>Accuracy:</b>	1.0 % Celsius
<b>Sealing:</b>	IP 65 (when connections mated/fitted with caps)
<b>Repeatability:</b>	1 °C
<b>Data Out:</b>	Digital data over 100M Ethernet (M12, 8 pin)
<b>Software:</b>	Complete Land Image Processing Software (LIPS) package for Windows
<b>Standard Accessories:</b>	Field Connection Box (ExHazloc) and cables (10 m, 25 m or 50 m), software, water cooled/purged mounting and tube
<b>Field of View (Horizontal):</b>	90°
<b>Focus Range:</b>	1000 mm to infinity
<b>Probe Length:</b>	305, 609 or 914 mm (12", 24" or 36")
<b>Probe Diameter:</b>	57 mm (2.24 in.) max.
<b>Mountings:</b>	Choice of 3" ANSI 150 RF Flange & Gasket or PN16 DN80 Flange & Gasket with a 12" standpipe
<b>Dimensions:</b>	254 x 560 x 717 mm (or 1021 mm or 1326 mm) 10" x 22" x 32" (or 44" or 56")
<b>Power Rating:</b>	21.6 - 26.4 V dc, 0.6 A
<b>Weight:</b>	< 25 kg (for 609 mm / 24" version)
<b>Hazardous Area Certification:</b> <i>EX Borescopes</i>	EX NIR-B WG1: Ex nA IIC T4 Gc Tamb=-20 °C to +55 °C (ATEX certificate: CML 15ATEX4086X / IECEx certificate: IECEx CML 15.0042X) EX NIR-B WG2: Class I, Division 2, Groups A, B, C, D; T4 Tamb=-20 °C to +60 °C (CSA certificate for US and Canada: 70080206)
<i>Field Connection Boxes</i>	EX FCB 31: Ex nA nC [op-is Ga] IIC T4 Gc Tamb=-25 °C to +54 °C (ATEX certificate: CML 15ATEX4085X) EX FCB 32: Class I, Division 2, Groups A, B, C, D; T4 Tamb=-25 °C to +50 °C (CSA certificate for US and Canada: 70052791)

DISCOVER HOW OUR BROAD RANGE  
OF NON-CONTACT TEMPERATURE  
MEASUREMENT AND COMBUSTION  
& EMISSIONS PRODUCTS OFFER A  
SOLUTION FOR YOUR PROCESS

WWW.LANDINST.COM | WWW.AMETEK.COM

**LAND**  
AMETEK®

**OneTemp**<sup>®</sup> pty ltd  
measure | control | record  
**1300 768 887**  
[www.onetemp.com.au](http://www.onetemp.com.au)

For a full list of international offices, please visit our website [www.landinst.com](http://www.landinst.com)  
Copyright © 2008-16 LAND Instruments International. Continuous product development may make it necessary to change these details without notice.  
MARCOM0377 NIR-B 3XR Rev 2



APPLIES IN THE UK



APPLIES IN THE US



Certificate No. C1200  
APPLIES IN INDIA