

## JUMO digiLine CR with separate sensor

### Intelligent electronic components for conductive conductivity sensors for automation systems with JUMO digiLine, IO-Link, analog or binary signals

#### Brief description

##### General

The JUMO digiLine CR allows sensors for electrolytic conductivity to be connected to a measuring and/or automation device. The JUMO digiLine CR is available with 4 different interface types for transferring measured values or switching signals, depending on the requirement:

- **RS485 interface** for the JUMO digiLine protocol and Modbus
- **IO-Link interface** for connecting to modern automation systems
- **Analog outputs** for transfer of the measured values as a standard signal of 4 to 20 mA
- **Binary outputs** for switching applications (e.g. controlling relays)

The versions with RS485 interface are used in JUMO digiLine operation with Plug & Play support on the JUMO AQUIS touch S/P or in Modbus operation on the JUMO mTRON T. Several sensors continuously transmit their measurement data over the bus to a master. The variant with IO-Link interface is an important supplement via which JUMO meets its customers' requirements in the modern world of automation technology.

Alternatively, device versions with analog and binary outputs are available. The analog version is fitted with 2 analog outputs and transfers temperature and conductivity measured values as a scaleable standard signal (4 to 20 mA). The version with binary outputs has 2 semi-conductor relay outputs (PhotoMOS®) for realizing switching applications. The device versions with analog and binary outputs also have 2 binary inputs. Via the binary inputs, the hold functions or measuring range selection can be actuated in the JUMO digiLine CR using potential-free contacts or logic signals.

#### Installation and connection

In the device version with a separate sensor, the conductivity sensor and JUMO digiLine electronics are two separate modules that are interconnected by a sensor line. The sensor is integrated at the operating location in a suitable fitting. The JUMO digiLine electronics can be mounted close to the sensor. The holder is used for mounting. It allows the JUMO digiLine electronics to be fastened to walls, pipes, masts and DIN rails. The electrical connection is made simply and quickly with pre-assembled cables via 2 M12 plug connectors or M12 sockets (sensor connection and interface connection), depending on interface type.

#### Configuration, parameterization and calibration

The JUMO digiLine CR is configured, parameterized and calibrated on the JUMO AQUIS touch S/P. In the JUMO digiLine CR device versions with display and operating panel, operation is also possible on the JUMO digiLine CR itself. The calibration, however, also be conveniently carried out in the laboratory on a PC using the JUMO DSM-Software (**D**igital **S**ensor **M**anagement software). For the connection to the PC, the JUMO digiLine CR has a Micro-B USB connection type.

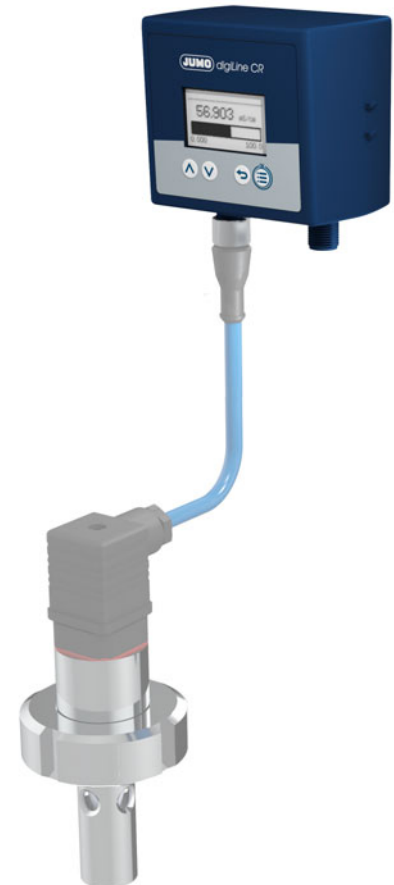

Type 202762

#### Special features

- Reliable transmission of measured values over digital interfaces such as the JUMO digiLine bus or IO-Link
- Easy, time-saving bus cable installation with read-to-use cable (available as accessory)
- Sensor calibration on a PC with storage of the calibration data in the JUMO digiLine electronics
- Easy and time-saving Plug & Play installation on the JUMO AQUIS touch S/P
- Extensive range of various interfaces for various customer requirements (JUMO digiLine, IO-Link, analog standard signals or binary switching signals)

## Block diagram

### JUMO digiLine CR with RS485 interface (JUMO digiLine and Modbus)

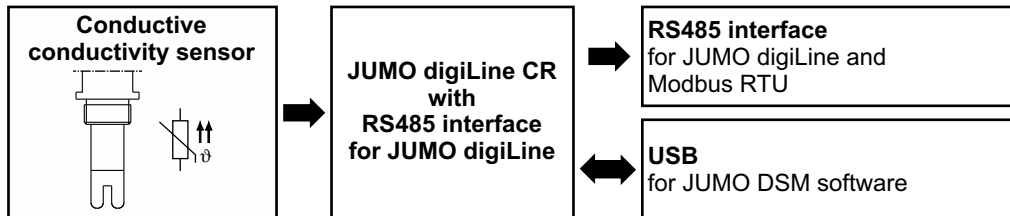

### JUMO digiLine CR with IO-Link interface

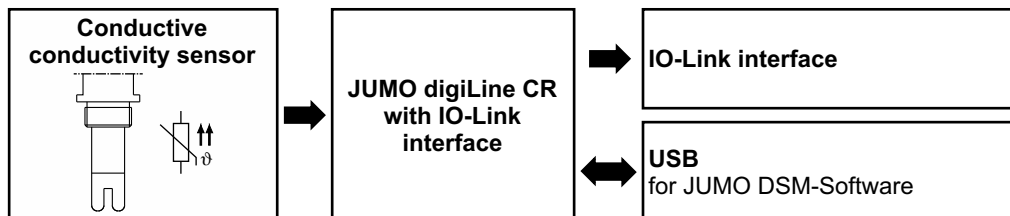

### JUMO digiLine CR with analog outputs

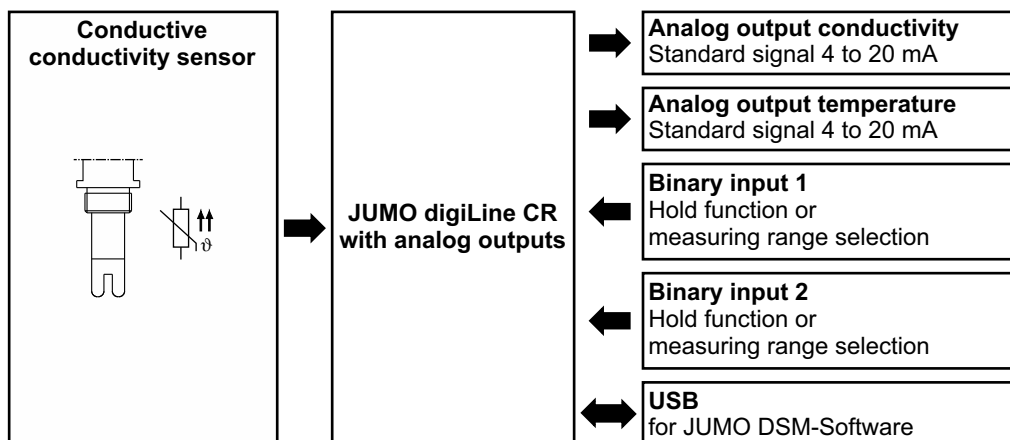

### JUMO digiLine CR with binary outputs

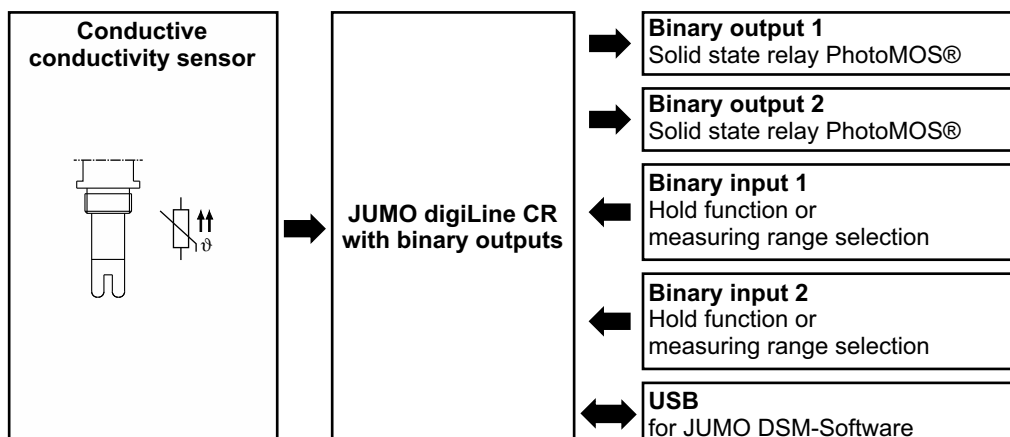

## Device setup

### JUMO digiLine electronics for CR-Sensors in device version with a separate sensor

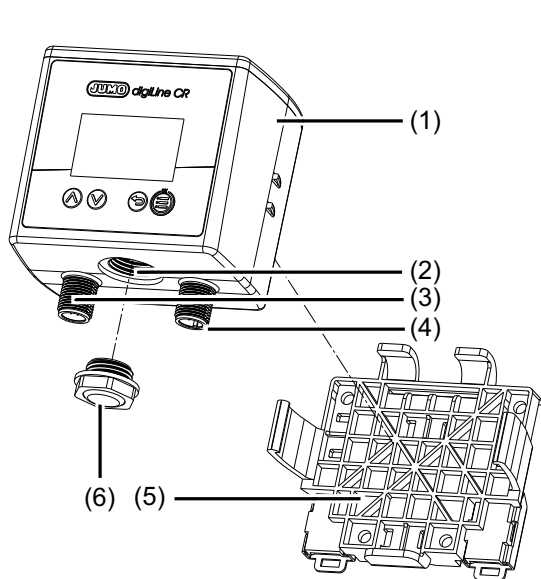

- 1) JUMO digiLine electronics for CR-Sensors
- 2) USB interface
- 3) M12 plug connector, 8-pole for sensor connection
- 4) M12 plug connector for output/input signals or interface connection (depending on device version)
- 5) Holder for wall, pipe and DIN rail mounting
- 6) Housing opening for USB interface (closed with venting element)

### JUMO digiLine device fronts CR

#### Device version with display and membrane keyboard

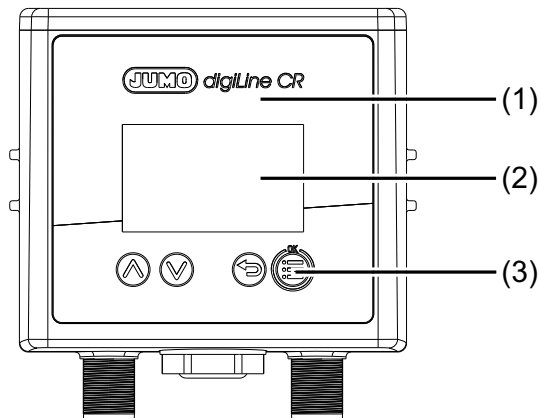

- 1) JUMO digiLine device front CR with operating panel
- 2) Display
- 3) Operating keys

#### Device version without display and membrane keyboard

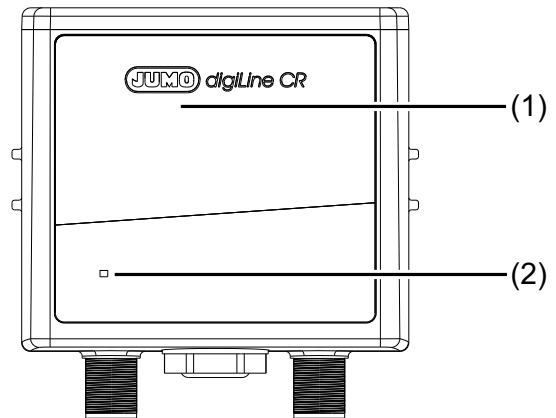

- 1) JUMO digiLine device front CR without operating panel
- 2) Status LED

## Description

### Device version RS485 interface for JUMO digiLine and Modbus RTU

This interface is used to connect to the JUMO digiLine bus system of the JUMO AQUIS touch S/P or to a JUMO mTRON T with Modbus interface.

The plug & play support for the JUMO digiLine electronics simplifies sensor startup considerably. After the JUMO AQUIS touch S/P is connected, the JUMO digiLine electronic components are configured automatically and ready for use immediately.

As an alternative to JUMO digiLine operation with plug & play support on the JUMO AQUIS touch S/P, Modbus operation (Modbus-RTU) on the JUMO mTRON T with access to the measured data is also possible. In this case, the JUMO digiLine electronics are configured and calibrated on the PC (USB interface) via the JUMO DSM software.

### Device version IO-Line interface

The device version with IO-Link interface permits integration into systems which use the IO-Link interface popular in automation technology. The IO Device Description (IODD) required to engineer the customer's automation devices is provided at [www.jumo.net](http://www.jumo.net) and <https://ioddfinder.io-link.com>. Further detailed information can be found online at [www.io-link.com](http://www.io-link.com) or in the relevant technical literature.

### Device version with analog outputs for standard signal 4 to 20 mA

The analog device version has 2 analog outputs and 2 binary inputs for actuation via external switching signals. At the analog outputs, conductivity and temperature measured values are output as freely-scalable standard signals 4 to 20 mA. The binary inputs can be actuated to actuate hold functions or measuring range selection, either with potential-free contacts or with 24-Volt logic signals.

### Device version with binary outputs solid state relay PhotoMOS®

The device version with binary outputs has 2 switching outputs with PhotoMOS® solid-state relays and 2 binary inputs for actuation via external switching signals. The binary outputs output the states of internal functions of the JUMO digiLine electronic components (e.g. limit value monitoring or sensor malfunction) as switching signals. The binary inputs can be actuated to actuate hold functions or measuring range selection, either with potential-free contacts or with 24-Volt logic signals.

### JUMO Digital Sensor Management Software for the PC

The JUMO DSM software (DSM stands for Digital Sensor Management) can be used to manage, calibrate, and test JUMO digiLine electronics on the PC. It also serves as a configuration tool for JUMO digiLine electronics in the device versions with analog and binary outputs. The connection to the PC is via the USB interface. The JUMO DSM software adds data from the memory of JUMO digiLine electronics to its sensor database. The sensor database holds calibration logbook entries, histories about replaced sensors and configuration changes to the JUMO digiLine electronics. If the JUMO digiLine electronics are to be operated with a new sensor (device versions with a separate sensor only), data for the new sensor can be reset via the JUMO DSM software and the information from the old sensor archived on the PC.

### Temperature compensation

Temperature compensation of the electrolytic conductance is handled by the digiLine electronic components. When conductivity sensors with integrated temperature probe is used, the JUMO digiLine electronics can obtain the temperature compensation directly from the sensor. Alternatively, the compensation temperature can be transmitted from the JUMO digiLine master device (JUMO AQUIS touch S/P) or the IO-Link master. As a third option, a fixed temperature can be specified in the configuration of the JUMO digiLine electronic components.

JUMO digiLine electronic components offer multiple temperature compensation methods (e.g. natural water, constant temperature coefficient, TC curve, and also various concentration curves) in the configuration for selection.

### Calibration

Calibration can be achieved either in the field on the JUMO AQUIS touch S/P or, if available, via the operating panel of the JUMO digiLine electronic components. It is also possible to calibrate at a lab workstation using the JUMO DSM software. The calibration data are saved in the JUMO digiLine electronics of the sensor. The sensor calibration can therefore be performed ahead of commissioning, so that the sensor with its JUMO digiLine electronics can then simply be mounted on the system. This reduces the plant downtime to a minimum when it becomes necessary to replace the sensor.

### Calibration timer

The JUMO digiLine electronic components have a calibration timer which, after a set calibration interval has lapsed, is able to trigger a

reminder for the due sensor calibration on the JUMO AQUIS touch S/P or IO-Link master. The calibration interval setting can be edited via the configuration menu of the JUMO AQUIS touch S/P, if present on the control panel of the JUMO digiLine electronic components, or using the JUMO DSM software. At each sensor calibration, the calibration interval is restarted.

### Calibration logbook

The JUMO digiLine electronics contain a calibration logbook in which the last 10 calibration operations are saved with the date, time, and calibration values. This logbook provides an overview of the calibration history of the sensor. The calibration logbook can be read-out either at the JUMO AQUIS touch S/P, if present on the control panel of the JUMO digiLine electronics or using the JUMO DSM software on the PC. There is no limit to the number of saved calibration logbook entries for JUMO digiLine electronics in the JUMO DSM software.

### Sensor information

Numerous data such as type information, operating data, information on measuring point identification etc. are stored in the JUMO digiLine electronics. This information allows clear identification and optimal management of each sensor. All these data can be viewed on the JUMO AQUIS touch S/P or using the JUMO DSM software. IO-Link master can also retrieve these data.

### Sensor monitoring

To monitor the stress on the sensor from sensor cleaning, counters are implemented for CIP and SIP cycles. CIP and SIP cycles are recognized automatically on the basis of the criteria specified in the configuration for sensor monitoring. The counters for the CIP and SIP cycles each retain the number of cleaning processes performed. The counter readings can be queried on the JUMO AQUIS touch S/P and retrieved by IO-Link masters in order to assess the wear status of the sensor. Upon reaching a configured counter reading, an alarm is signaled on the JUMO digiLine master and, if present, the JUMO digiLine CR/Ci. After a sensor has been replaced, the counters are reset with the JUMO DSM software.

### Limit value monitoring function

On device versions with binary outputs or an IO-Link interface, 2 limit value monitoring functions with 4 selectable basic mathematical switching functions each (Min. alarm, Max. alarm, Alarm window and Alarm window inverted) are available. The limit value can be

permanently configured. In addition, it is also possible to set limit value alarms acc. to USP <645> or the European Pharmacopoeia (Ph. Eur.) for purified water.

If necessary, suppression of limit value alarms that occur when switching the device on and when changing the measuring range can be configured.

Limit value monitoring can be used to monitor the analog values of the temperature and conductivity measurement inputs. The limit value alarm signals can be configured as the signal source for the binary inputs and, on device versions with binary outputs, also for the alarm buzzer of the device.

### **Alarm buzzer**

For audible signaling of alarms, the device version with binary outputs features an alarm buzzer.

It can be linked simultaneously to 3 internal binary signals. If one of these signals triggers an alarm, an audible alarm is generated, either for a limited period of time or until all alarms are acknowledged, depending on the configuration.

### **Sensor stress**

To assess the stress on the sensor from the thermal, the current "sensor stress" is calculated on the basis of the measurement data provided by the sensor. In the JUMO digiLine electronic components, a sensor stress alarm signal can be configured. If a critical sensor stress level is reached, this signals a sensor stress alarm on the master device and, where available, on the display of the JUMO digiLine electronic components.

### **Customer-specific characteristic lines**

For each measuring range, a linearization table with up to 30 value pairs each can be activated in the JUMO digiLine electronic components. These show the measured electrolytic conductance to any unit (e.g. a concentration value derived from the conductance). The JUMO digiLine linearization tables CR can be used during operation without a master device to provide customer-specific linearization of the measured value on the local display on device versions with a display. The linearization tables of the JUMO digiLine electronic components are deactivated for operation on the JUMO AQUIS touch S/P. The customer-specific linearization of the JUMO AQUIS touch S/P is available and should be used.

## Technical data

### RS485 interface for JUMO digiLine or Modbus

Protocol	JUMO digiLine <sup>a</sup> or Modbus RTU <sup>b</sup>
Device address	1 to 247
Data formats <sup>c</sup>	8 - 1 - no parity 8 - 2 - no parity 8 - 1 - odd parity 8 - 1 - even parity
Baud rates	9600 baud 19200 baud 38400 baud
adjustable minimum response time	0 to 500 ms

<sup>a</sup> The JUMO digiLine protocol assigns the interface parameters automatically during startup (Plug & Play).

<sup>b</sup> The Modbus RTU protocol is used to operate the JUMO digiLine electronics on a JUMO mTRON T CPU. For operation on a JUMO mTRON T, the interface parameters must be set prior to initial commissioning with the JUMO DSM software.

<sup>c</sup> Specification in useful bit - stop bit - parity format.

### IO-Link interface

Communication interface	IO-Link device V 1.1 (downward compatible to V 1.0)
Communication mode (data transfer rate)	COM 3 (230.4 kBaud)
IO Device Description (IODD)	The IODD can be localized via the "IODDfinder" on the JUMO website in the product area for this device or at <a href="http://www.io-link.com">www.io-link.com</a> and downloaded.
Max. cable length acc. to IO-Link standard	20 m
Output mode	
Switching output type	Transistor switching output can be configured as NPN, PNP or Push/Pull
short-circuit proof	Yes (clocked)
resistant to overload	Yes
protected against polarity reversal	Yes
Ampacity of the switching outputs	100 mA in each case
Voltage drop of the switching outputs	max. 2 V in each case

### Analog outputs 4 to 20 mA

Signal range	4 to 20 mA
Maximum load resistance	≤ 500 Ω
Accuracy	0.25 %
Ambient temperature influence	0.08 % / 10 K

### Binary outputs

Type	Solid state relay PhotoMOS®
Ampacity	200 mA
Max. voltage	DC 50 V, AC 35 V

## Analog inputs (sensor connection side)

### Input for temperature sensor

Measuring range	
Pt100	-50 to +250 °C
Pt1000	-50 to +250 °C
Connection types	2-wire/3-wire
Measuring accuracy	±0.25 % of MR <sup>a</sup>
Ambient temperature influence	0.1 % / 10 K
Sampling rate	500 ms

<sup>a</sup> MR: measuring range span

### Input for CR conductivity sensor

Units	μS/cm mS/cm kΩ × cm MΩ × cm
Display ranges <sup>a</sup>	0.000 to 9.999 00.00 to 99.99 000.0 to 999.9 0000 to 9999
Temperature compensation	TC linear <sup>b</sup> for -50 to +250 °C and over 0.045 μS/cm TC curve <sup>b</sup> for -20 to +150 °C and over 0.055 μS/cm TDS <sup>c</sup> for -50 to +250 °C Natural water DIN EN 27888 for 0 to 36 °C Natural water with expanded range for 0 to 100 °C ASTM D1125-95 neutral impurities for 0 to 100 °C and over 0.045 μS/cm ASTM D1125-95 alkali and acid impurities for 0 to 100 °C and over 0.055 μS/cm
Measuring accuracy	0 to 20 μS      ±(0.5 % of the MRE <sup>d</sup> + 0.3 μS) × cell constant 0 to 100 μS    ±(0.6 % of the MRE <sup>d</sup> + 0.3 μS) × cell constant 0 to 1000 μS   ±(0.6 % of the MRE <sup>d</sup> + 0.3 μS) × cell constant 0 to 10 mS     ±(0.6 % of the MRE <sup>d</sup> + 0.3 μS) × cell constant 0 to 100 mS    ±(0.6 % of the MRE <sup>d</sup> + 0.3 μS) × cell constant 0 to 1000 mS   ±1 % of MRE <sup>d</sup>
Cell constant	0.01 to 10 cm <sup>-1</sup>
Measuring range selection	
Device versions with analog / binary output	2 configurable measuring ranges
Device versions with RS485 / IO-Link interface	4 configurable measuring ranges
Ambient temperature influence	0.2 % / 10 K
Sampling rate	500 ms

<sup>a</sup> The measuring/display range is scalable. The decimal place is user configurable.

<sup>b</sup> TC: temperature coefficient

<sup>c</sup> TDS (Total Dissolved Solids)

<sup>d</sup> MRE: Measuring range end value

## Input for CR junior conductivity sensor

Units	$\mu\text{S}/\text{cm}$ $\text{mS}/\text{cm}$ $\text{k}\Omega \times \text{cm}$ $\text{M}\Omega \times \text{cm}$												
Display ranges <sup>a</sup>	0.000 to 9.999 00.00 to 99.99 000.0 to 999.9 0000 to 9999												
Temperature compensation	TC linear <sup>b</sup> for -50 to +250 °C TDS <sup>c</sup> for -50 to +250 °C Natural water DIN EN 27888 for 0 to 36 °C Natural water with expanded range for 0 to 100 °C												
Measuring accuracy	<table border="0"> <tr> <td>0 to 20 <math>\mu\text{S}</math></td> <td><math>\pm(1\% \text{ of the MRE}^d + 0.3 \mu\text{S}) \times \text{cell constant}</math></td> </tr> <tr> <td>0 to 125 <math>\mu\text{S}</math></td> <td><math>\pm(1\% \text{ of the MRE}^d + 0.3 \mu\text{S}) \times \text{cell constant}</math></td> </tr> <tr> <td>0 to 1000 <math>\mu\text{S}</math></td> <td><math>\pm(1\% \text{ of the MRE}^d + 0.3 \mu\text{S}) \times \text{cell constant}</math></td> </tr> <tr> <td>0 to 10 mS</td> <td><math>\pm(1\% \text{ of the MRE}^d + 0.3 \mu\text{S}) \times \text{cell constant}</math></td> </tr> <tr> <td>0 to 100 mS</td> <td><math>\pm(1\% \text{ of the MRE}^d + 0.3 \mu\text{S}) \times \text{cell constant}</math></td> </tr> <tr> <td>0 to 200 mS</td> <td><math>\pm(2\% \text{ of the MRE}^d + 0.3 \mu\text{S}) \times \text{cell constant}</math></td> </tr> </table>	0 to 20 $\mu\text{S}$	$\pm(1\% \text{ of the MRE}^d + 0.3 \mu\text{S}) \times \text{cell constant}$	0 to 125 $\mu\text{S}$	$\pm(1\% \text{ of the MRE}^d + 0.3 \mu\text{S}) \times \text{cell constant}$	0 to 1000 $\mu\text{S}$	$\pm(1\% \text{ of the MRE}^d + 0.3 \mu\text{S}) \times \text{cell constant}$	0 to 10 mS	$\pm(1\% \text{ of the MRE}^d + 0.3 \mu\text{S}) \times \text{cell constant}$	0 to 100 mS	$\pm(1\% \text{ of the MRE}^d + 0.3 \mu\text{S}) \times \text{cell constant}$	0 to 200 mS	$\pm(2\% \text{ of the MRE}^d + 0.3 \mu\text{S}) \times \text{cell constant}$
0 to 20 $\mu\text{S}$	$\pm(1\% \text{ of the MRE}^d + 0.3 \mu\text{S}) \times \text{cell constant}$												
0 to 125 $\mu\text{S}$	$\pm(1\% \text{ of the MRE}^d + 0.3 \mu\text{S}) \times \text{cell constant}$												
0 to 1000 $\mu\text{S}$	$\pm(1\% \text{ of the MRE}^d + 0.3 \mu\text{S}) \times \text{cell constant}$												
0 to 10 mS	$\pm(1\% \text{ of the MRE}^d + 0.3 \mu\text{S}) \times \text{cell constant}$												
0 to 100 mS	$\pm(1\% \text{ of the MRE}^d + 0.3 \mu\text{S}) \times \text{cell constant}$												
0 to 200 mS	$\pm(2\% \text{ of the MRE}^d + 0.3 \mu\text{S}) \times \text{cell constant}$												
Cell constant	0.01 to 10 $\text{cm}^{-1}$												
Ambient temperature influence	0.5 % / 10 K												
Sampling rate	500 ms												

<sup>a</sup> The measuring/display range is scalable. The decimal place is user configurable.

<sup>b</sup> TC: temperature coefficient

<sup>c</sup> TDS (Total Dissolved Solids)

<sup>d</sup> MRE: Measuring range end value

## Binary input (only for device versions with analog or binary output)

Signal type	Switching thresholds	
	On	Off
Potential-free contact	< 800 $\Omega$	> 1.5 k $\Omega$
Logic input (external voltage supply max. DC 28 V)	> 6 V	< 5 V

## Electrical data

### Device versions with RS485 interface

Voltage supply <sup>ab</sup>	DC 4.5 to 5.5 V or DC 18 to 30 V
Power/current consumption	< 3 W
Electromagnetic compatibility (EMC)	DIN EN 61326-1
Interference emission	Class B <sup>c</sup>
Interference immunity	Industrial requirements
Protection rating	Protection rating III

<sup>a</sup> The voltage supply for the JUMO digiLine electronics must be provided with SELV or PELV and must meet the requirements for energy-limited electrical circuits to DIN EN 61010-1.

<sup>b</sup> The power supply current must be limited to 2 A. If the voltage supply allows higher current consumption, a fuse must be provided.

<sup>c</sup> The product is suitable for industrial use as well as for households and small businesses.

### Device versions with IO-Link

Voltage supply <sup>ab</sup>	DC 18 to 30 V
Power/current consumption	< 3 W
Electromagnetic compatibility (EMC) Interference emission Interference immunity	DIN EN 61326-1 Class B <sup>c</sup> Industrial requirements
Protection rating	Protection rating III

<sup>a</sup> The voltage supply for the JUMO digiLine electronics must be provided with SELV or PELV and must meet the requirements for energy-limited electrical circuits to DIN EN 61010-1.

<sup>b</sup> The power supply current must be limited to 2 A. If the voltage supply allows higher current consumption, a fuse must be provided.

<sup>c</sup> The product is suitable for industrial use as well as for households and small businesses.

### Device versions with analog or binary outputs

Voltage supply <sup>ab</sup>	DC 20 to 30 V
Power/current consumption Device versions with analog outputs Device versions with binary outputs	≤ 4 W ≤ 3 W
Electromagnetic compatibility (EMC) Interference emission Interference immunity	DIN EN 61326-1 Class B <sup>c</sup> Industrial requirements
Protection rating	Protection rating III

<sup>a</sup> The voltage supply for the JUMO digiLine electronics must be provided with SELV or PELV and must meet the requirements for energy-limited electrical circuits to DIN EN 61010-1.

<sup>b</sup> The power supply current must be limited to 2 A. If the voltage supply allows higher current consumption, a fuse must be provided.

<sup>c</sup> The product is suitable for industrial use as well as for households and small businesses.

### Case

Material	Plastic (ABS)
Protection type	IP66, IP67, IP69K
Operating position	any, with due consideration for the viewing angle of the display

### Environmental influences

Ambient temperature	-20 to +60 °C
Storage temperature	-25 to +80 °C
Shock resistance Acceleration Duration	DIN EN 60654-3 40 m/s <sup>2</sup> Duration 5 ms
Vibration resistance Frequency range Deflection Acceleration	IEC 61298-3 10 to 150 Hz 0.75 mm 2 m/s <sup>2</sup>
Resistance to climatic conditions	Climate class 4K4H to EN 60721-3-4 Relative humidity ≤ 100 % condensing

## Approvals and approval marks

Approval mark	Test facility	Certificate/certification number	Inspection basis
DNV GL	DNV GL	Approval submitted	Class Guideline DNVGL-CG-0339
c UL us	Underwriters Laboratories,	Approval submitted	UL 61010-1 (3rd Edition), CAN/CSA-C22.2 No. 61010-1 (3rd Edition)
GOST	-	Approval submitted	-
EAC	RU	Approval submitted	-

## Connection diagram

### five-pole M12 plug connector for RS485 (JUMO digiLine or Modbus RTU)

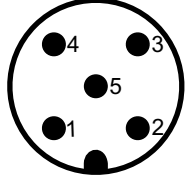
Pin	Potential	Symbol
1	+5 V	Plug connection 
2	+ 24 V	
3	GND	
4	RS 485 B (RxD/TxD-)	
5	RS 485 A (RxD/TxD+)	
The connection to the serial interface of a master with screw or spring-cage terminals is made with the aid of the JUMO digiLine device connection cable (see Accessories)		

### 4-pole M12 plug connector for IO-Link

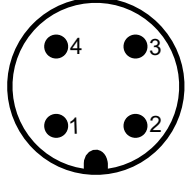
Pin	Potential	Symbol
1	+24 V	Plug connection 
2	Binary output 2	
3	GND	
4	IO-Link communication connection/binary output 1	

### 8-pole M12 socket for binary outputs

Pin	Potential	Symbol
1	Binary input 1	Socket 
2	Binary input 2	
3	+ solid state relay 1	
4	- solid state relay 1	
5	+ solid state relay 2	
6	- solid state relay 2	
7	+ 24 V	
8	GND	

### 8-pole M12 bushing for analog outputs

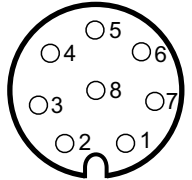
Pin	Potential	Symbol
1	Binary input 1	Socket 
2	Binary input 2	
3	+ analog output measured value electrolytic conductance	
4	- analog output measured value electrolytic conductance	
5	+ analog output temperature measured value	
6	- analog output temperature measured value	
7	+ 24 V	
8	GND	

## Sensor connection



A connecting cable with wire end ferrules on the sensor end is available for the JUMO digiLine CR in device versions with a separate sensor (see accessories). This cable must be provided with a cable socket suitable for the selected sensor and connected in accordance with the following table.

### CAUTION!

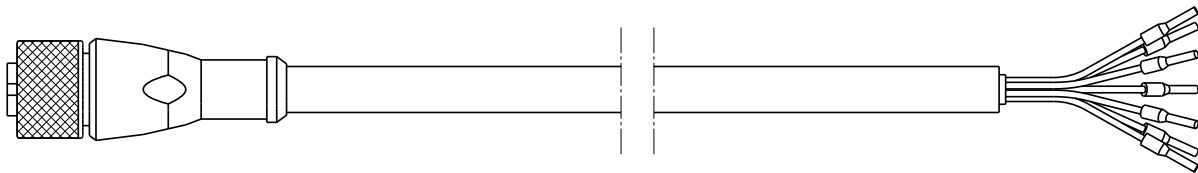
► The connecting cable must be routed directly to the transmitter, not over terminal blocks.

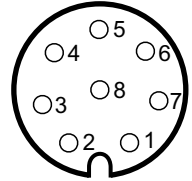

**8-pole sensor connection**

Pin	Wire color	Function	Symbol
1	Red	Outer electrode 1	<div style="text-align: center;">Socket</div>  <div style="text-align: center;">Connection side</div> 
2	Gray	Inner electrode 1	
3	Yellow	Temperature 1	
4	Green	Temperature 2	
5	Pink	Inner electrode 2	
6	blue	Outer electrode 2	
7	Brown	Temperature 3	
8	White	Shield	

**5-pole sensor connections**

Sensor connecting cable 8-pole			Sensor-side connections		
Pin	Wire color	Function	Angular connector on the sensor	Fixed cable on the sensor	M12 connector 5-pole on the sensor
1	Red	Outer electrode 1		White	1
2	Gray	Inner electrode 1			
3	Yellow	Temperature 1	1 <sup>a</sup>	Yellow <sup>a</sup>	3 <sup>b</sup>
4	Green	Temperature 2	3 <sup>a</sup>	Green <sup>a</sup>	4 <sup>b</sup>
5	Pink	Inner electrode 2	2	Brown	2
6	blue	Outer electrode 2			
7	Brown	Temperature 3	3 <sup>a</sup>	-	5 <sup>b</sup>
8	White	Shield	-	Shield	-

<sup>a</sup> 2-wire circuit

<sup>b</sup> 3-wire circuit

## Galvanic isolation

### JUMO digiLine CR with RS485 interface (JUMO digiLine and Modbus)

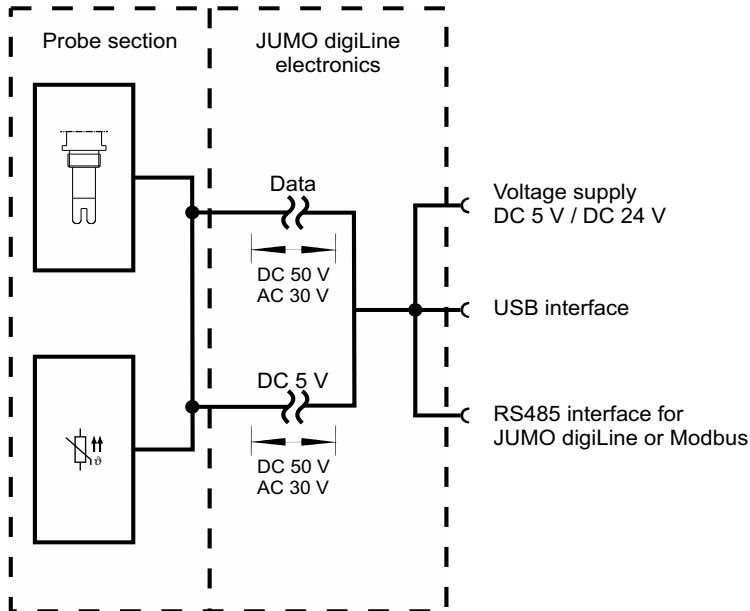

### JUMO digiLine CR with IO-Link interface

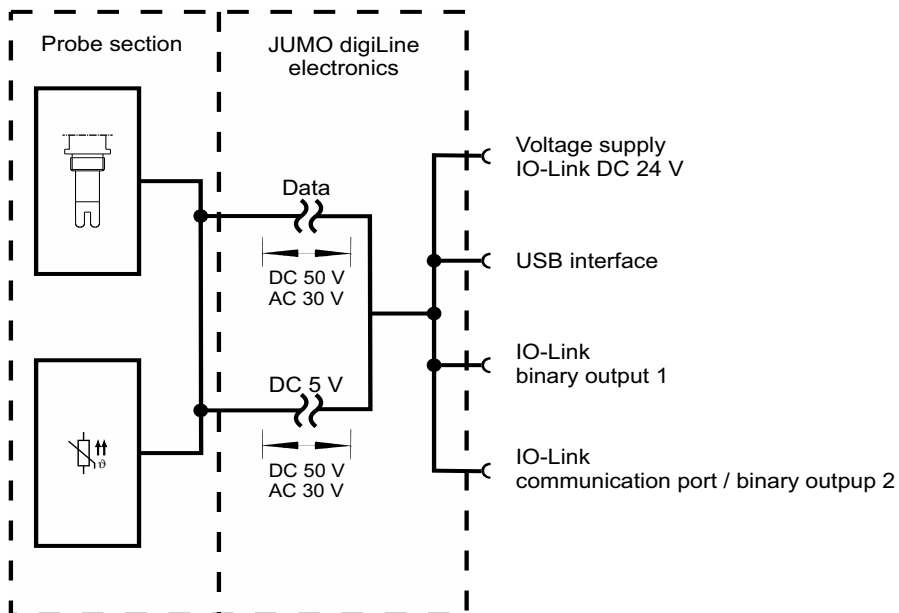

## JUMO digiLine CR with analog outputs

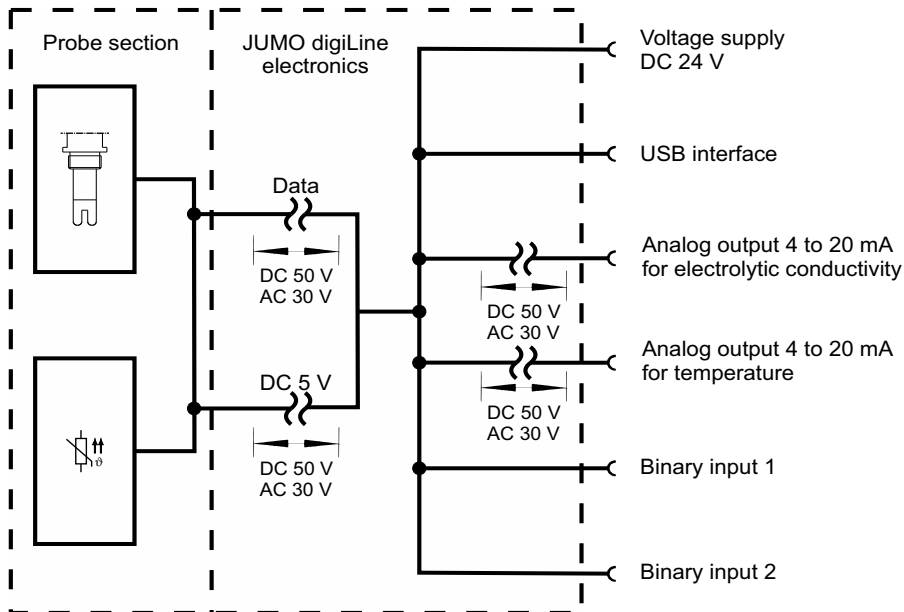

## JUMO digiLine CR with binary outputs

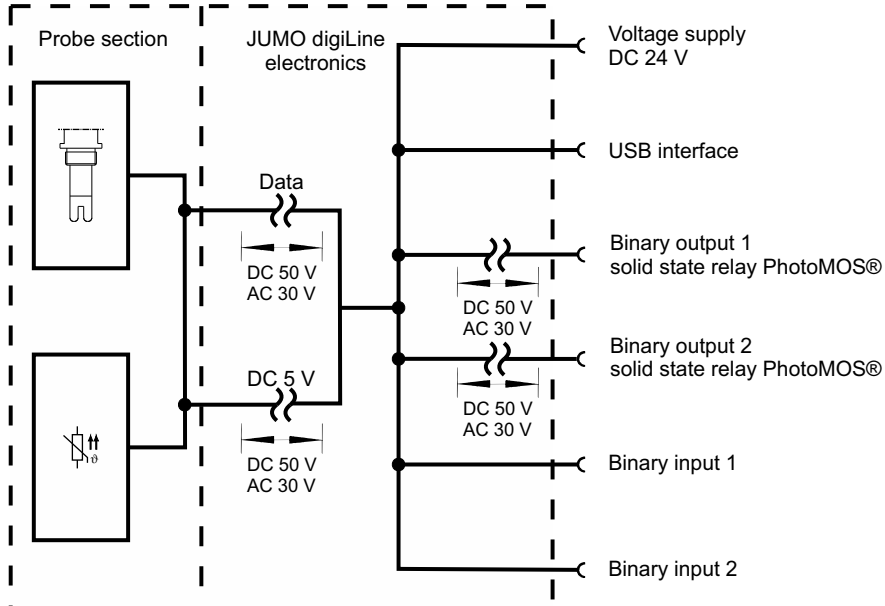

## Connection examples

### JUMO digiLine mode

The graphic shows the installation example of a system with 3 sensors (pH, conductive conductance and temperature) with JUMO digiLine pH/ORP/T and JUMO digiLine CR connected to a JUMO AQUIS touch S. The bus subscribers on the JUMO digiLine bus are connected to one another via a JUMO digiLine hub and M12 connecting cables. Appropriate fittings are available from JUMO for mounting the sensors.

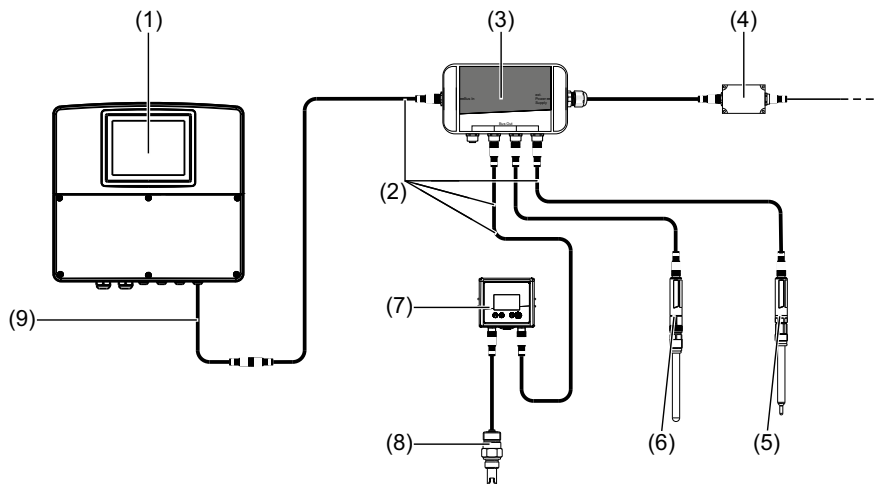

- (1) JUMO AQUIS touch S with RS485 bus terminator in the device
- (2) JUMO M12 connecting cable, five-pole and A-coded;  
the required total line length between master and sensors can be achieved by combining several M12 connecting cables. When planning the line lengths, heed the information regarding cable planning in the Annex of the operating manual for the JUMO AQUIS touch S/P.
- (3) JUMO digiLine hub with 4× M12 sockets and 1× M12 plug connector, each 5-pole A-coded; supply DC 24 V with separate power supply unit
- (4) separate DC 24 V power supply unit for the voltage supply to the JUMO digiLine-bus system
- (5) JUMO compensation thermometer with five-pole JUMO digiLine T  
Order example: compensation thermometer 201085/89-1005-21-120 with  
JUMO digiLine-T: 202705/30/86-530
- (6) JUMO pH-sensor with five-pole JUMO digiLine pH  
Order example: pH-Sensor 201021/10/12-04-22-120/000 with  
JUMO digiLine-pH: 202705/10/86-530
- (7) JUMO digiLine CR in the wired device version
- (8) Conductivity sensor
- (9) JUMO digiLine master connecting cable with exposed wire ends at one end for connection to devices with screw or spring-cage terminals (see Accessories); connection is described in the operating manual of the JUMO AQUIS touch S/P.

## Operation of JUMO digiLine CR in the device version with RS485 interface on the JUMO mTRON T

The graphic shows the connection of 1 sensor with JUMO digiLine pH/ORP/T with 5-pole M12-plug connection and 1 conductivity sensor with JUMO digiLine CR in the device version with RS485 interface on a JUMO mTRON T as Modbus master. Up to 31 digital sensors per RS485 interface can be integrated. Optionally, a JUMO mTRON T central processing unit can be equipped with up to 2 RS485 interfaces (see order data for JUMO mTRON T).

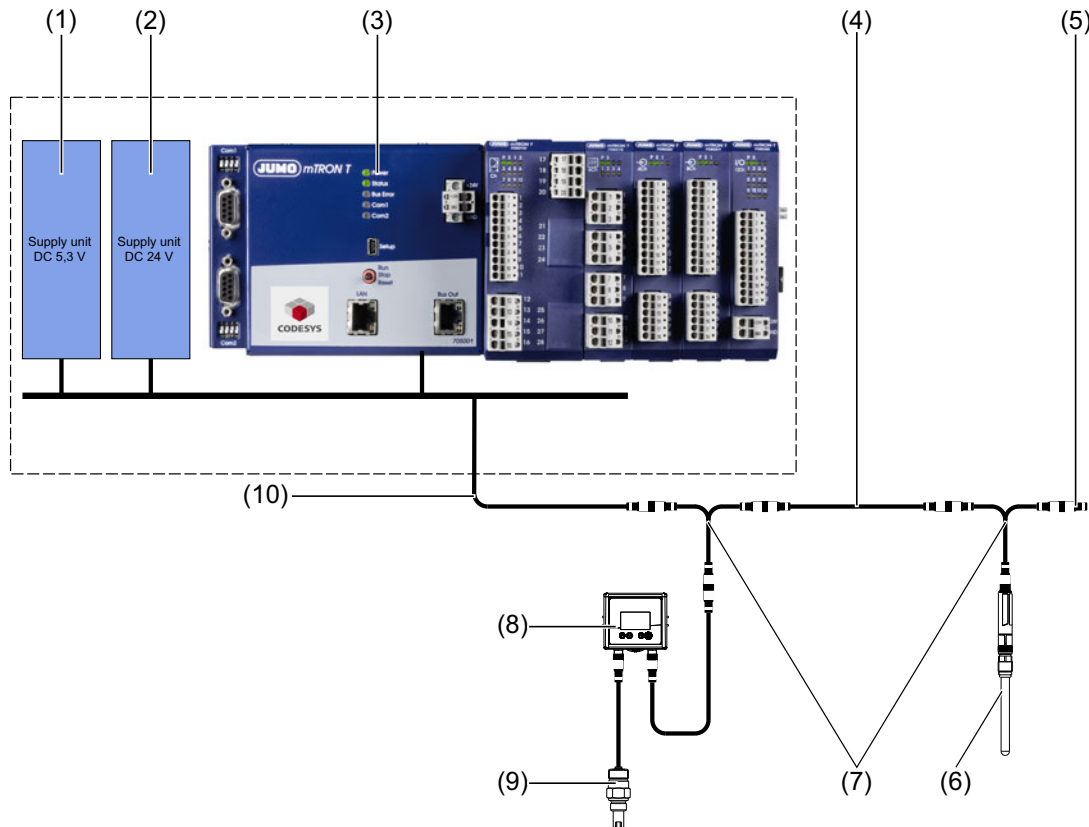

- (1) Stabilized power supply unit with DC 5.3 V output for feeding sensors with JUMO digiLine pH/ORP/T 5-pole (current limiting via 2 A fuse required)
- (2) Stabilized power supply unit with DC 24 V output for feeding sensors with JUMO digiLine CR and JUMO mTRON T (current limiting via 2 A fuse required)
- (3) JUMO mTRON T central processing unit with activated PLC function and RS422/485 Modbus RTU (see order data for JUMO mTRON T)
- (4) JUMO M12 connecting cable, 5-pole and A-coded
- (5) JUMO M12 terminating connector, 5-pole for bus termination
- (6) JUMO sensors with JUMO digiLine pH/ORP/T five-pole
- (7) JUMO Y-splitter, 5-pole with 2× M12 cable sockets and 1× M12 connector, each of which is A-coded
- (8) JUMO digiLine CR in device version with RS485 interface
- (9) Conductivity sensor
- (10) JUMO digiLine master connecting cable with open wire ends at one end for connection to devices with screw or spring-cage terminals (see Accessories); for connection to the Modbus system, refer to the wiring diagram in the following.

## Wiring diagram for Modbus mode

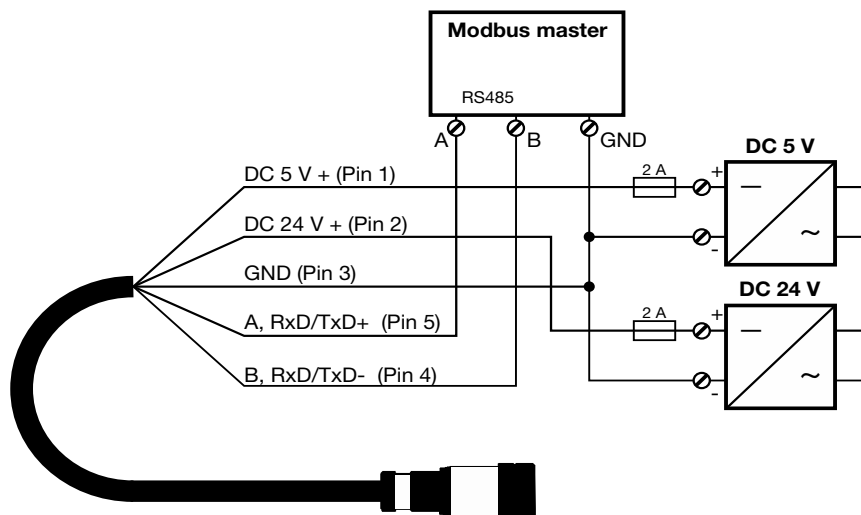

## JUMO digiLine CR in device version with analog outputs (standard signal of 4 to 20 mA)

The illustration shows connection of a conductivity sensor with JUMO digiLine CR in the device version with analog outputs to a measuring or automation device that uses standard signals of 4 to 20 mA. In addition, 2 binary signals (depending on configuration, potential-free contacts or logic signals) from the receiving automation device that can be used to activate the hold function or select one of the 4 measuring range configurations via the binary input of the JUMO digiLine electronics can be connected. The JUMO digiLine electronics with analog outputs of 4 to 20 mA is configured and calibrated from a PC using the JUMO DSM software or directly on the device in the case of device versions with a display and membrane keyboard.

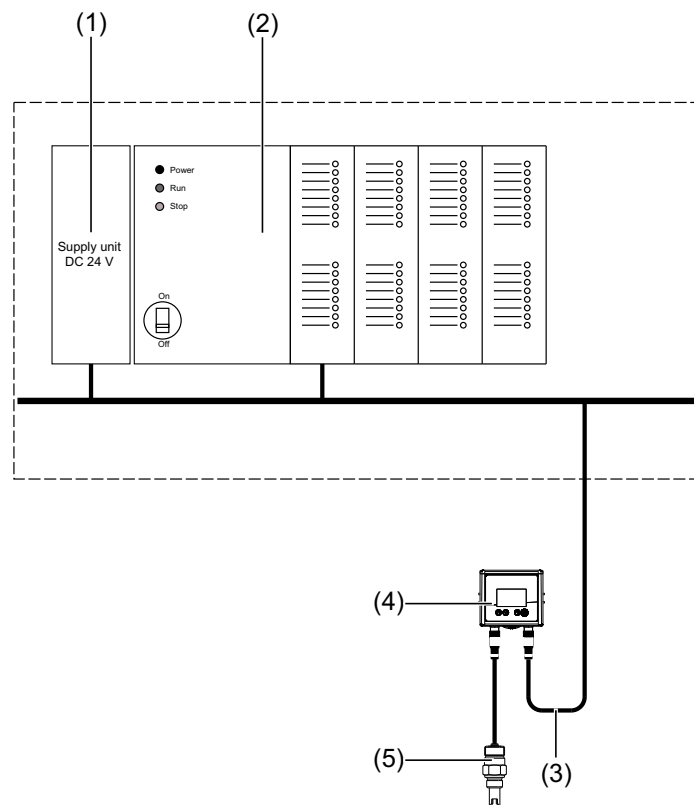

- (1) Stabilized power supply unit with DC 24 V output to supply the automation system and the JUMO digiLine electronics
- (2) Measuring or automation device with analog inputs for standard signal 4 to 20 mA and control contacts for measuring range parameter selection in the JUMO digiLine electronics.
- (3) Customer-provided connecting cable with 8-pole M12 connector (see chapter "Accessories", Page 25) for connecting to the JUMO digiLine CR in the version with analog outputs; for the connector assignment, refer to the wiring diagram in the following.
- (4) JUMO digiLine CR in device version with analog outputs
- (5) Conductivity sensor

### Wiring diagram for transmitter mode

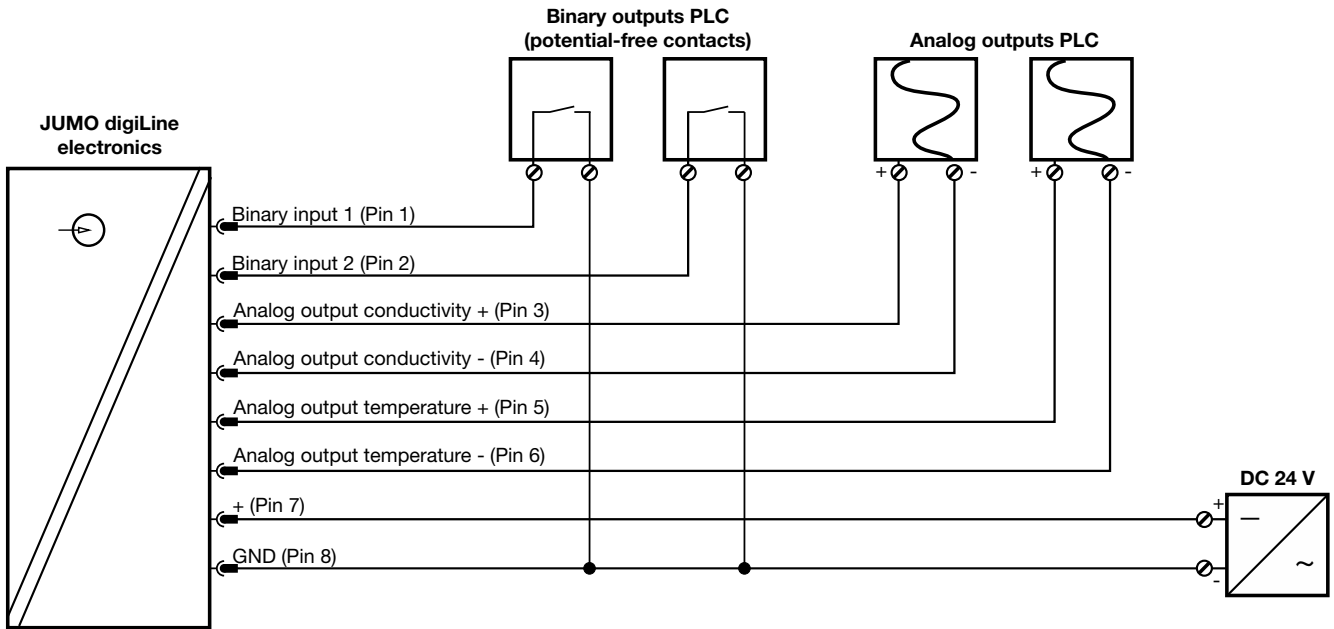

## Dimensions

### Dimensions of the JUMO digiLine electronics with digital interfaces

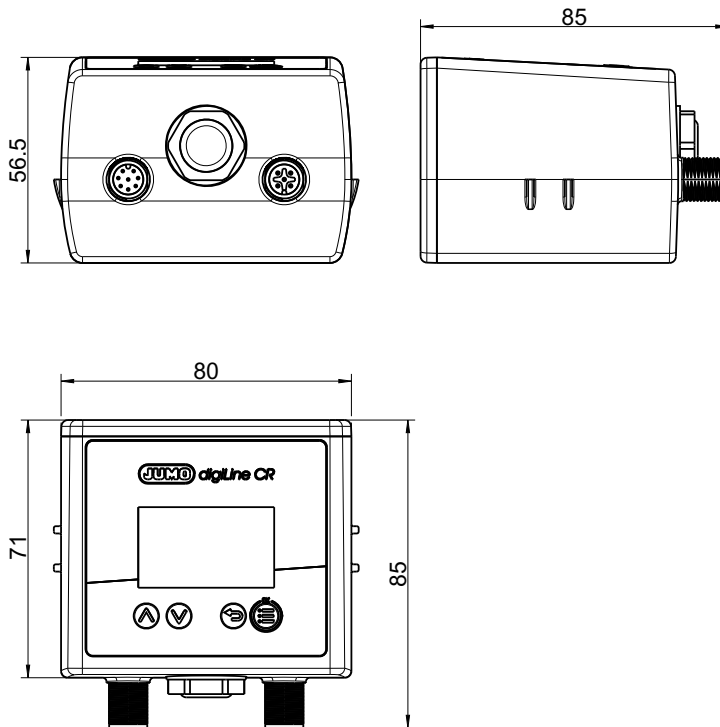

### Dimensions of the JUMO digiLine electronics with analog/binary outputs

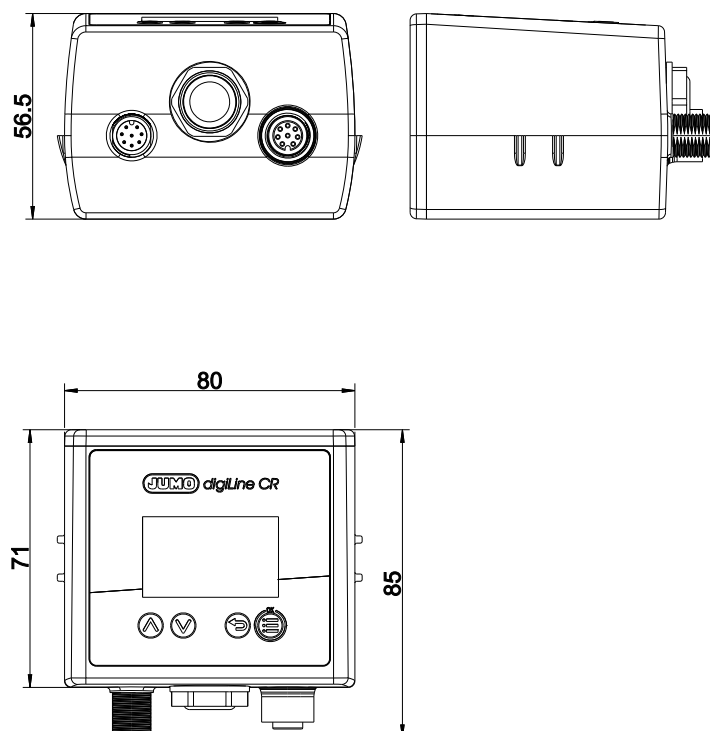

## Dimensions of the mounting plate for wall, pipe and DIN rail mounting

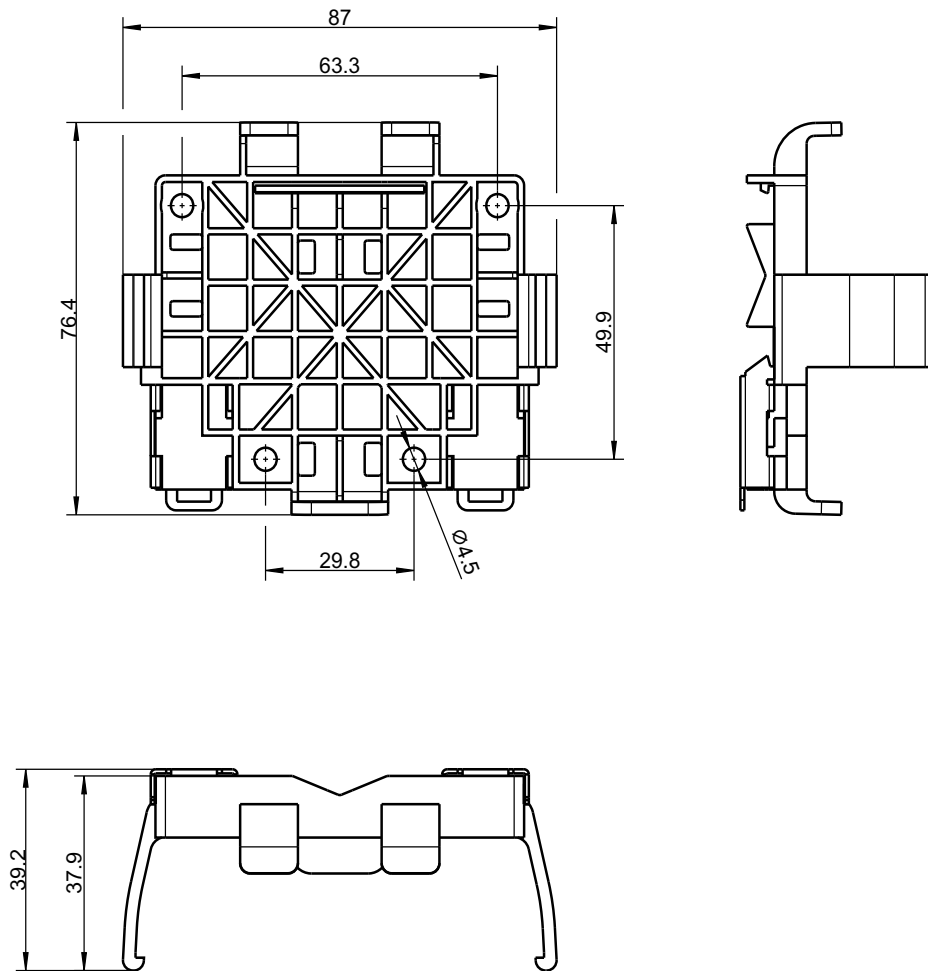

## Mounting

### Wall mounting

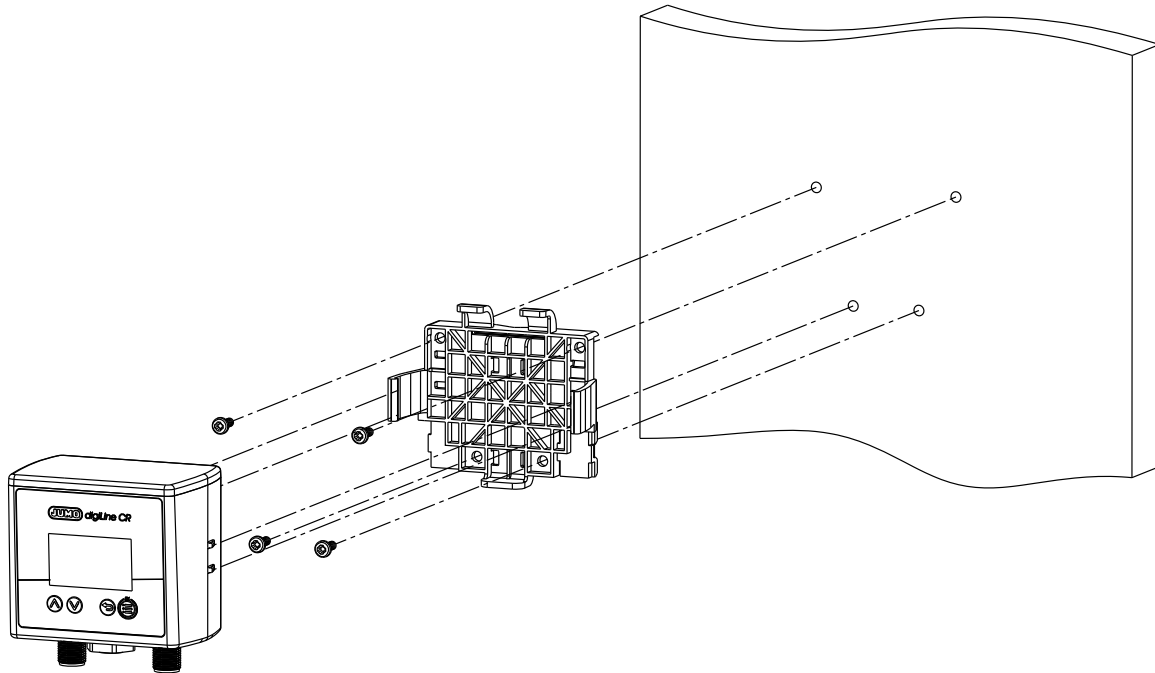

### Pipe mounting

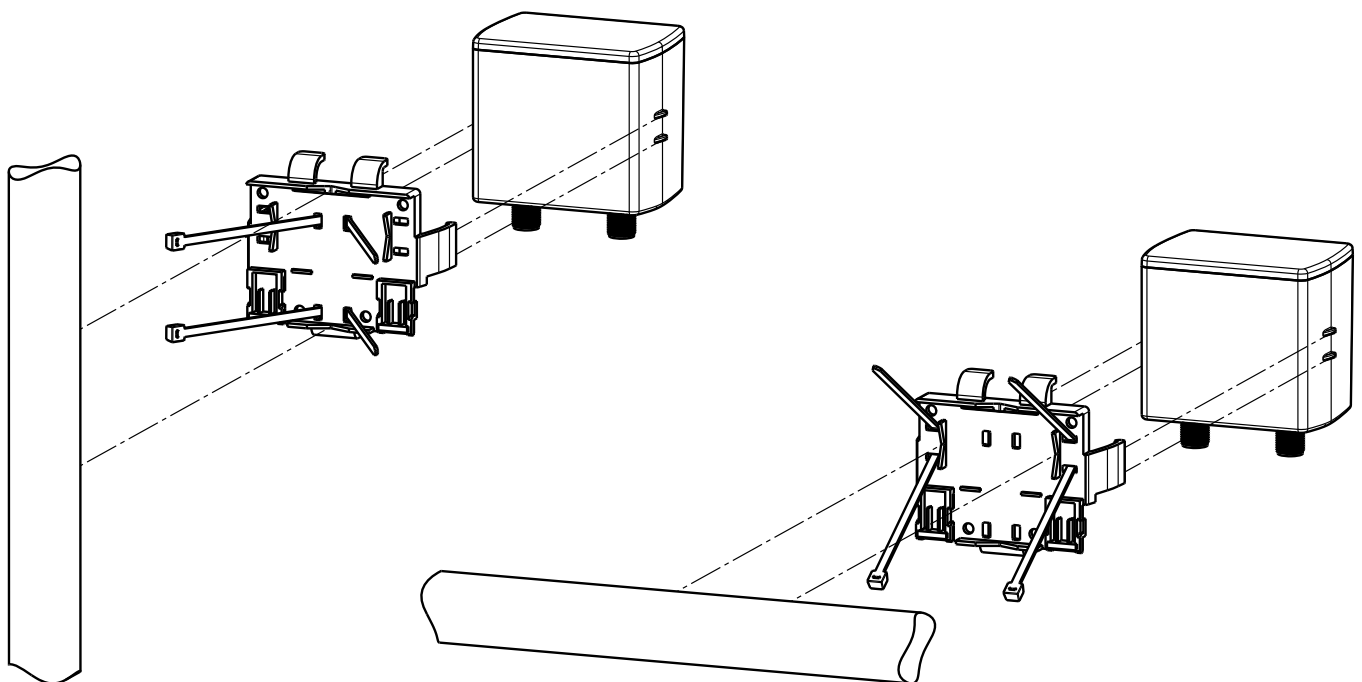

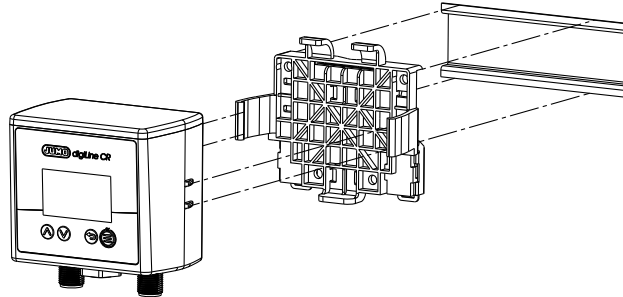
**DIN-rail mounting**



## Accessories

### Accessories

Type	Part no.
JUMO M12 digiLine master connecting cable <sup>a</sup> , 5-pole, A-coded, length 10 m	00638341
JUMO M12-digiLine master connecting cable <sup>a</sup> 5-pole, A-coded 5 m long	00638337
JUMO M12-digiLine master connecting cable <sup>a</sup> 5-pole, A-coded 1.5 m long	00638333
JUMO M12 connecting cable five-pole 15 m	00638324
JUMO M12 connecting cable five-pole 10 m	00638322
JUMO M12 connecting cable five-pole 5 m	00638315
JUMO M12 connecting cable five-pole 1.5 m	00638313
JUMO M12 connecting cable five-pole 0.5 m	00638312
JUMO Y-splitter 5-pole	00638327
JUMO digiLine hub	00646871
JUMO power supply unit for JUMO digiLine hub	00661597
JUMO M12 terminating connector	00461591
8-pin M12 connector	00444307
JUMO DSM software ( <b>D</b> igital <b>S</b> ensor <b>M</b> anagement)	00655787
Sensor connection cable with M12 cable socket, 8-pole, with the ferrules at sensor end, 1.5 m long	00710954
Sensor connection cable with M12 cable socket, 8-pole, with the ferrules at sensor end, 5 m long	00710951
Sensor connection cable with M12 cable socket, 8-pole, with the ferrules at sensor end, 10 m long	00709544
M12 cable socket, 8-pole	00444312
M12 cable socket, 8-pole, shielded	00486503
IO-Link master upon request	
Device data (IODD) at <a href="http://www.jumo.de">www.jumo.de</a> or at <a href="http://ioddfinder.io-link.com">http://ioddfinder.io-link.com</a>	

<sup>a</sup> For connection to masters with screw or spring-cage terminals; prepare one end of the cable with a 5-pole M12 socket and the other end with ferrules.

## Notes on trademark

PhotoMOS® is a registered trademark of Panasonic.