



Remote Monitoring for Business

Wireless CO2 - Carbon Dioxide Sensors

General Description

The [ALTA Wireless Carbon Dioxide Sensor](#) uses an ultra low-power, high-performance CO₂ sensor to measure the amount of carbon dioxide in ambient air.

- Measures 0 to 10000 ppm CO₂
- Accurate to +/- 45 ppm + 3% of reading
- Sensor produces instantaneous CO₂ readings and 8 hour time weighted average(TWA) readings

Principle of Operation

The ALTA Wireless Carbon Dioxide Sensor measures the amount of CO₂ in the ambient air surrounding the element. It is programmed to take readings at a set interval to accurately calculate CO₂ levels, then send the time-stamped data to the iMonnit Online Sensor Monitoring and Notification System at user-specified time intervals (sensor heartbeat). The CO₂ data can be reviewed and exported as a data sheet or graph and notifications can be set up through the online system to alert the user when defined thresholds have been met or exceeded.

Use Cases

- [Greenhouses](#)

Example Applications

- Indoor air quality
- [Greenhouses](#)
- Cellar and gas stores
- Marine vessels
- Modified atmospheres
- Landfill gas
- Confined spaces
- Cryogenics
- Ventilation management
- [Additional applications](#)

Features of Monnit ALTA Sensors

- Wireless range of 1,200+ feet through 12+ walls *
- Frequency-Hopping Spread Spectrum (FHSS)
- Improved interference immunity
- Improved power management for longer battery life **
- Encrypt-RF® Security (Diffie-Hellman Key Exchange + AES-128 CBC for sensor data messages)
- All ALTA sensors now have up to 3200 readings:
 - 10-minute heartbeats = 22 days
 - 2-hour heartbeats = 266 days
- Over-the-air updates (future proof)
- Free iMonnit basic online wireless sensor monitoring and notification system to configure sensors, view data and set alerts via SMS text and email

* Actual range may vary depending on environment.

** Battery life is determined by sensor reporting frequency and other variables. Other power options are also available.

Wireless Range Comparison

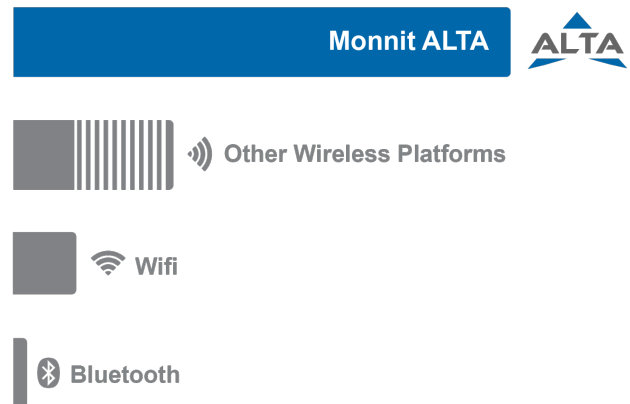

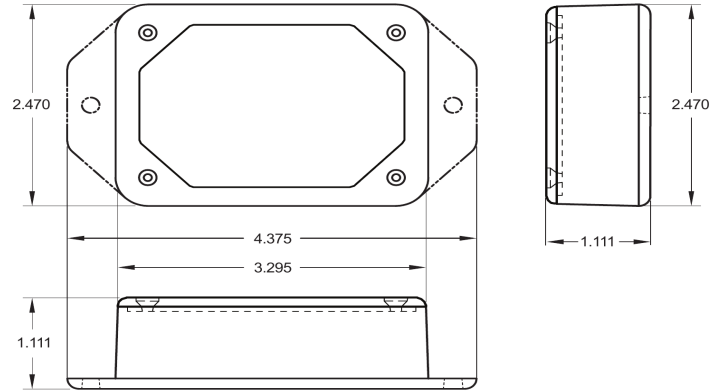

ALTA Commercial AA Wireless Carbon Dioxide Sensor | Technical Specifications

Supply voltage	2.0–3.8 VDC (3.0–3.8 VDC using power supply) *	
Current consumption	0.2 μ A (sleep mode) 0.7 μ A (RTC sleep) 570 μ A (MCU Idle)	2.5 mA (MCU Active) 5.5 mA (Radio RX Mode) 22.6 mA (Radio TX Mode)
Operating temperature range (sensor and CO ₂ element)	0°C to 50°C (32°F to 122°F) standard range	
Operating humidity range (sensor and CO ₂ element)	0% to 95% (non-condensing)	
Recommended storage temperature (no batteries)	-30°C to +70°C (-22°F to +158°F)	
Sensing method	Non-dispersive infrared (NDIR) absorption Gold-plated optics Solid-state source and detector	
Sample method	Diffusion	
Measurement range	0 to 10000 ppm CO ₂	
Accuracy	+/- (45 ppm + 3%) * (1 + .0013 * Δ P)) **	
Calibration	Autocalibration **	
Non linearity	< 1% of FS	
Pressure dependence	0.13% of reading per mm Hg in normal atmospheric conditions	
Response time	3 minutes	
Integrated memory	Up to 3200 sensor messages	
Wireless range	1,200+ ft non-line-of-sight	
Security	Encrypt-RF® (256-bit key exchange and AES-128 CTR)	
Weight	4.5 ounces	
Certifications	 900 MHz product; FCC ID: ZTL-G2SC1 and IC:9794A-G2SC1. 868 and 433 MHz product tested and found to comply with: EN 300 220-2 V3.1.1	

* Please take care when connecting a power device.

** Δ P is in mbar and is the difference between atmospheric pressure at sea level (1013 mbar) and the pressure at the sensors altitude (Ex: 1013 mbar – ambient pressure in mbar).

*** For correct autocalibration, the sensor must experience fresh air CO₂ levels (~400 ppm) for at least 4 hours per day. If the environment does not meet this criteria then disable the autocalibration feature.

Power Options

The standard version of this sensor is powered by two replaceable 1.5 V AA sized batteries (included with purchase). This sensor is also available with a line power option. The line powered version of this sensor has a barrel power connector allowing it to be powered by a standard 3.0–3.6 V power supply. The line powered version also uses two standard 1.5 V AA batteries as backup for uninterrupted operation in the event of line power outage. Power options must be selected at time of purchase, as the internal hardware of the sensor must be changed to support the selected power requirements.

Commercial Grade Sensors

Monnit commercial grade sensors are designed for applications in ordinary environments (normal room [temperature](#), [humidity](#) and [atmospheric pressure](#)). Do not use these sensors under the following conditions as these factors can deteriorate the product characteristics and cause failures and burnout.

- Corrosive gas or deoxidizing gas: chlorine gas, hydrogen sulfide gas, ammonia gas, sulfuric acid gas, nitric oxides gas, etc.
- Volatile or flammable gas
- Dusty conditions
- Low-pressure or high-pressure environments
- Wet or excessively humid locations
- Places with salt water, oils chemical liquids or organic solvents
- Where there are excessively strong vibrations
- Other places where similar hazardous conditions exist

Use these products within the specified temperature range. Higher temperature may cause deterioration of the characteristics or the material quality.